

STUDY CASE OVER AN AGRICULTURE SPRAYER EQUIPMENT USING MULTIAXIAL FATIGUE CRITERIA COMPARED WITH EXPERIMENTAL RESULTS.

Roberto I. Rodrigues¹, Felipe Giordani², Gustavo Giordani¹, Ignácio Iturrioz¹, Jakson Vassoler¹, Joel Boaretto³

¹Mechanical Engineering Post-Graduate Program, Federal University of Rio Grande do Sul

Av. Sarmiento Leite 425, 90050-170, Porto Alegre, Brazil

roberto.ir@hotmail.com, giordani2112@hotmail.com, ignacio.iturrioz@ufrgs.br, jmvassoler@ufrgs.br

²AGCO, Av. Guilherme Schell 10260, 92420-910, Canoas, Brazil

felipe.giordani@agcocorp.com

³Randon Center of Technology

Road Arziro Galafassi, 95180-000, Farroupilha, Brazil

joel.boaretto@ctrandon.com

Abstract. In many situations in engineering, the fatigue phenomenon determine the catastrophic collapse of the structure generating a significant loss in material resources and human life. The analysis of the real problem is in general complex. On the other hand, the classic fatigue criteria approach is reasonably well established. However, the methodologies based on these criteria are not applied directly when some complexities are part of the problem. Examples such as the excitation generated by multiaxial stress or strain states, ; the proximity to the weld region; among other situations that could happen in real problems. In the present case, a component of an agricultural sprayer is analyzed. Over the cited structure, an experimental verification was carried out. Also, a finite element method was applied to determine the level of stresses/strains in the critical region. In the present work, different fatigue multiaxial criteria, Findley; McDiarmid; Brown and Miller, Fatemi and Socie and Carpinteri Spagnoli were analyzed. The Wang Brown method was applied to count the equivalent cycles, considering the multiaxial nature of the load history. Therefore, a comparison with real field observations could be performed, leading to the evaluation of the proposed methodologies and their associated advantages and disadvantages. Additionally, the implementation based on a nonproportional nature, considering the multiaxial stress history, was developed.

Keywords: Fatigue, Multiaxial Loading, Random Loading,

1 Introduction

Fillet welded joints are a common connection type in a broad range of components. This type of joint offers many advantages to structures such as lightweight, high flexibility, cost-saving and simplified manufacturing processes. Despite that benefits, welded parts normally are the most fragile parts and the failure usually occurs in the welded region. In agricultural applications, usually, joints are submitted to multiaxial random loadings since non-paved roads stress the structure. Therefore, it is crucial to have a method that can verify the multiaxial random loads in proportional and non-proportional cases.

The studied problem have not had a clear solution in the literature yet, multiaxial non proportional problems in fatigue, especially considering random loadings, need an analyzes of the each case to determine the model to be applied to find the solution, there is not a consolidated methodology that can be applied to several different cases. Takahashi [1] and Skibicki [2] show a more detailed analysis of the question.

Considering that the main goal of this paper is to compare different models of multiaxial fatigue analysis to determine their advantages and disadvantages and combine then to a multiaxial cycle counting method that

allows to solve random loading problems, and apply the proposed methodology in a real problem.

2 METHODOLOGY

2.1 Component Analyzed

A sprayer, an agricultural machine used to pulverize herbicides and fungicides to preserve crops against harmful insects and herbs, was the equipment chosen to be analyzed with the methods described in the previous sections. The equipment is shown in Figure 1. It had a real problem of fracture by multiaxial high-cycle fatigue in the weld region during service with around 2000h of usage as reported by users. The failure is shown in Figure 2. Figure 3 shows the geometry of the analyzed area. The component was already studied by Carpinteri et al. [3], Giordani [4], Vandatori [5] and Rodrigues [6] with the application of other methods or an equivalent loading.



Figure 1 – The sprayer



Figure 2 – The failure in the weld area

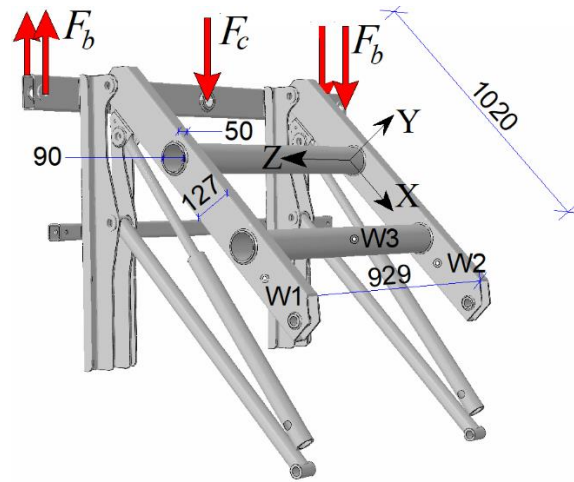

Figure 3. H component: geometrical sizes (in mm), loading condition and control points.

2.2 Multiaxial random loading characterization

The characterization of the random loading in the T-joint during its lifespan was defined with 12 maneuvers, that consider typical solicitations over the equipment during its life. It was estimated how long each maneuver takes during normal usage, while the experimental data was collected from a field test, in which it was possible to replicate all the maneuvers. This data allowed us to estimate the loading for the 2000h time-history by repeating each maneuver proportionally, considering the duration and the lifespan of the equipment. These data are summarized in Table 1.

Table 1 – Loading characterization

Maneuver	Fuel Tank	Time (h) for 2000h	Acquired time (s)
Application of the herbicide (cultivated area)	Full	450	180
	Empty	450	140
Application of the herbicide (perimeter)	Full	200	40
	Empty	200	52
Braking	Full	50	9,84
	Empty	50	23
U - curves	Full	100	150
	Empty	100	39
Travel on unpaved road	Full	100	115,4
	Empty	100	45,5
Perimeter curves	Full	100	9,84
	Empty	100	36,5

Control points were selected to measure local strains during the field test with the formation presented in Figure 3 (W1, W2 and W3 Note that, taken into account a given maneuver, an averaging operation (due to symmetry reason) was performed on the maximum principal strain time histories at point W1 and W2, and one time history is obtained.

The application of finite element models enables to simulate the behavior of the structure with some determined independent loadings, as shown in Figure 3 (F_b , F_c). More details about the finite element model can be found in Giordani [4]. The material is a C25E steel, which mechanical properties, fatigue properties and the S-N curve are listed in Rodrigues[6].

Initially, four forces F_b were applied to the FE model, each one equal to 1N (in such a case the F_c force was taken equal to zero). The FE analysis resulted in a maximum principal strain at point W1 close to zero, while at point W3, this value was ten-fold higher. Besides, the force F_c was applied to the FE model, equal to 1N (in such a case the F_b forces were taken equal to zero). The FE analysis resulted in a maximum principal strain at

point W3 close to zero, while at point W1, this value was 110 times higher. Therefore, the maximum principal strain at point W1, named $\varepsilon_{1,c}^{num}$, was only linked to the force F_c , while at point W3, named $\varepsilon_{3,b}^{num}$, was only linked to the forces F_b . Under linear elastic assumption, the numerical loading condition to simulate the actual one, relatively to each maneuver (m), that is F_b^m and F_c^m ($1 \leq m \leq 12$), were obtained multiplying their unit value (F_b and F_c) for the strain ratios $\varepsilon_{3,b}^{num,m}/\varepsilon_{3,b}^{exp,m}$ and $\varepsilon_{1,c}^{num,m}/\varepsilon_{1,c}^{exp,m}$, for each $1 \leq m \leq 12$. Therefore, combining the experimental data with the Finite Element Model, it is possible to extrapolate the strains values from the points W1, W2 and W3 to the failure region.

2.3 Damage evaluation

Each semi cycle generated by the Wang and Brown counting method is applied in the (i) Findley, (ii) McDiarmid and (iii) Fatemi and Socie methods of critical plane. More details about the used methods can be found in Findley[7], McDiarmid[8], Fatemi and Socie[9], Socie and Marquis[10] and Wang and Brown[11]. The critical plane criterion is the one proposed by Findley, that chooses the plane with maximum damage. For this evaluation, it is necessary to test all the semi cycles in every single plane considering a step of 1 degree. With the results for every single plane, the Palmgren-Miner Rule was applied as proposed by Miner [12]. After that, the damage value was obtained for each plane and the plane with the highest value is the critical one. This process is repeated for all points of interest. The analyzed area corresponds to the Brace and the Chord connected by welds, where the actual failure occurs. This region is shown in Figure 4.

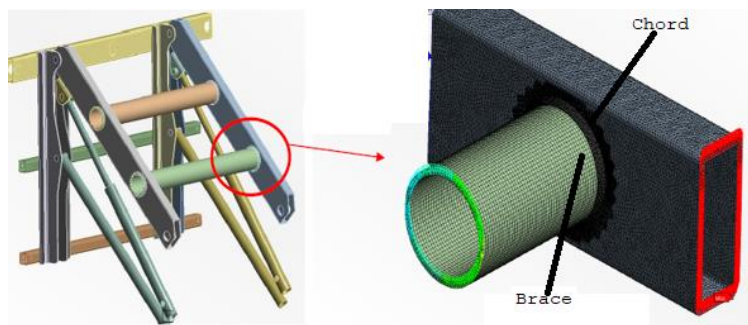

Figure 4. Analyzed region

3 RESULTS AND DISCUSSION

Figures 5 and 6 show the damage results around brace and chord, respectively. The damage values to angles superior to 180° are very close to zero and they were omitted from the graphic. Figure 7 shows the results with the Carpinteri method. More details can be found in Vandatori et al. [13].

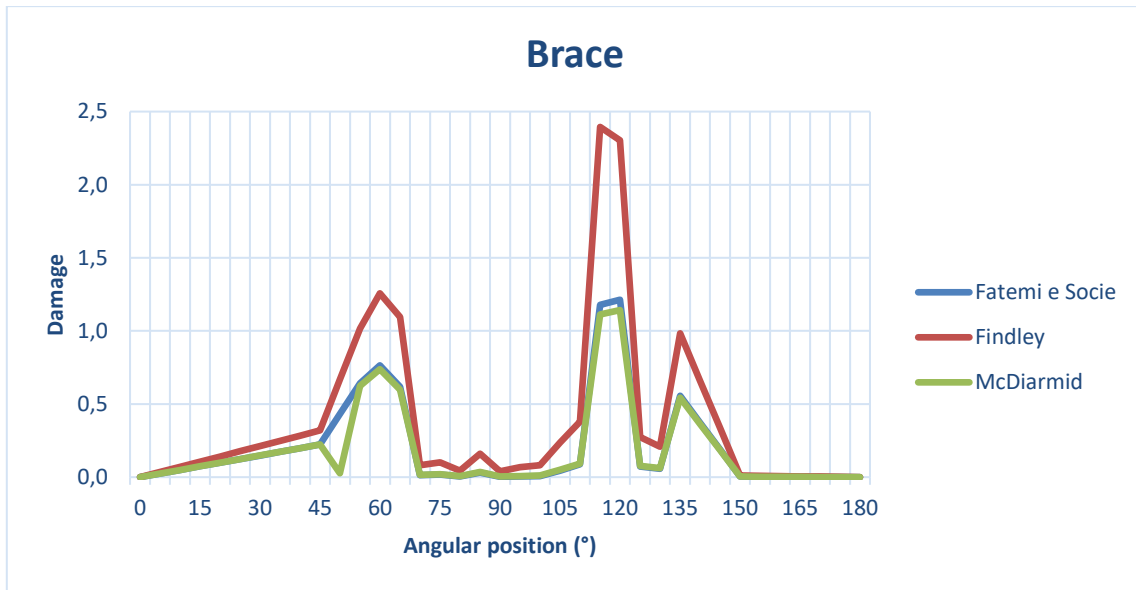

Figure 5. Damage results on the brace



Figure 6. Damage results on the chord area

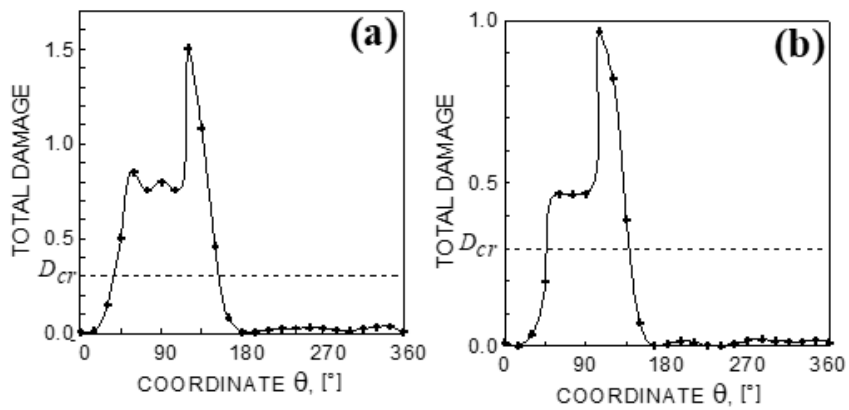

Figure 7. Total damage vs. the coordinate θ : (a) chord and (b) brace.

The critical area is around 55° and 120° in both methodologies, considering that the Carpinteri results do not use the Wang and Brown cycle counting method, it is possible to conclude that the Wang and Brown cycle counted method was corrected implemented in combination to the multiaxial fatigue methods used. Also, in the real component failure the region of failure was around 120° .

The results of the McDiarmid method was closer to the Carpinteri method and to the expected damage of 1 in the failure region. It is also important to note that all the method produced conservative results, so they expect that the component would have failed before the 2000h, as shown in **Table 2**.

Table 2. Lifespan of the component

Findley	McDiarmid	Fatemi e Socie	Carpinteri	Real
545 h	1695 h	1550 h	1307 h	2000 h

All three analyzed methods of multiaxial fatigue find close results within the expected error for fatigue analysis. At the point of maximum damage, located at 120° on the Chord, it is possible to observe that the difference in the results is close to a factor of 3. This difference can be explained by how the McDiarmid and Findley methods consider the influence of the normal stress on the problem. While McDiarmid uses a relation that considers the type of crack and the ultimate strength stress, Findley only considers the type of loading through the parameter k. Numerically in the analyzed problem, the parameter k of Findley is equal to 0.3, and the relation between the ultimate strength and the fatigue limit from McDiarmid is equal to 0.048. The loading produces predominantly shear stresses, so this fact justifies that the McDiarmid method obtained better results than the Findley method because the fatigue life is lesser sensible to the normal stress in the McDiarmid than the Findley criteria.

Considering that the analyzed component is under a loading in which the shear influence is dominant over normal influence, this fact justifies that the McDiarmid method obtained better results than Findley method.

The Fatemi and Socie method has a hybrid formulation which considers normal stress and shear strain. The normal stress influence is controlled by the material parameters and non-proportionality factors, such as hardening. However, in this study, it was not added non-proportional elements in the formulation. Even so, the Fatemi and Socie method obtained excellent results. Table 3 is shown the non-proportionality factor of the loading. The low values encountered may justify the reason that the McDiarmid method had the best results even with no non-proportionality factor included on its formulation.

Table 6. Non-Proportionality Factor

Normal Stress x	0,020
Normal Stress z	0,049

4 Conclusions

In the present paper is presented a novel procedure that combines existent methods for multiaxial fatigue analyze with a cycle counting method which permit to enlarge its application to include random loadings. The procedure was verified through an analysis in a welded tubular T-joint under random multiaxial non-proportional loading. This joint belongs to a H component constituted by welded tubes in an arm of a sprayer, an agricultural machine which spread pesticides in agricultural applications. The entire structure is submitted to a random multiaxial loading. To validate the process, a comparison with other method was also made. The main conclusions of the paper are:

- The proposed procedure was effectively able to calculate the lifespan of the component inside the expected error. Even when considering the different models applied.
- The proposed procedure was effective in predicting the region of failure.

- The McDiarmid model presented the best results, although the low value of the non-proportionality factor may influence on this result
- The Carpinteri model presents similar results, even considering a different counting cycle method.

References

- [1] Takahashi, B.X. Metodologia Moderna para Análise de Fadiga Baseada em Elementos Finitos de Componentes sujeitos a Fadiga Uni e Multiaxial. Master Thesis, USP, São Paulo, 2014 [in Portuguese]
- [2] Skibicki, D. Phenomena and Computational Models of Non-Proportional Fatigue of Materials. Ed. Springer, 2014.
- [3] Carpinteri A., Boaretto J., Fortese G., Giordani F., Isoppo Rodrigues R., Iturrioz I., Ronchei C., Scorza D., Vantadori S., Zanichelli A., Welded joints under multiaxial non-proportional loading, Theoretical and Applied Fracture Mechanics 2018; 93: 202-210.
- [4] Giordani F A. Estudo de Metodologias para medir a vida em fadiga Multiaxial não proporcional, Master Thesis, Promec/UFRGS, Brazil, 2015 [in Portuguese]. <http://hdl.handle.net/10183/118864>.
- [5] Vantadori S., Boaretto J., Fortese G., Giordani F., Rodrigues R.I., Iturrioz I., Ronchei C., Scorza D., Zanichelli A., Fatigue strength of welded joints under multiaxial non-proportional loading, Procedia Structural Integrity 2017; 5: 761-768.
- [6] Rodrigues, R.I Comparação de Métodos de Análise em Problemas de Fadiga Multiaxial Não-Proporcional, Master Thesis, Promec/UFRGS, Brazil, 2020 [in Portuguese]
- [7] Findley, W.N. A Theory for the Effect of Mean Stress on Fatigue of Metals under Torsion and Axial Load or Bending. Journal of Engineering for Industry, p.301-306, November 1959
- [8] McDiarmid, D.L. A Shear Stress Based Critical-Plane Criterion of Multiaxial Fatigue Failure for Design and Life Prediction. Fatigue and Fracture Engineering Materials and Structures, Vol 17, No 12, p 1475 – 1485, 1994.
- [9] Fatemi, A. e Socie D.F. A Critical Plane Approach to Multiaxial Fatigue Damage Including Out-of-Phase Loading. Fatigue and Fracture of Engineering Materials and Structures, Vol. 11, No. 3, p. 149 – 166, 1988.
- [10] Socie, D.F e Marquis, G.B. Multiaxial Fatigue. Society of Automotive Engineers, United States, 2000.
- [11] Wang, C.H. e Brown, M.W. A Path-Independent Parameter for Fatigue Under Proportional and Nonproportional Loading. Fatigue and Fracture of Engineering Materials and Structure, Vol.16, No.12, 1993, p. 1285-1298
- [12] Miner, M.A. Cumulative Damage in Fatigue. **Journal of Applied Mechanics**, v. 67, p. A159 – A164, 1945.
- [13] Vandadori, S., Iturrioz, I., Carpinteri, A., Greco, F. e Ronchei C. A Novel Procedure for Damage Evaluation in Filled Welded Joints. **International Journal of Fatigue**, Vol. 136, July 2020.